

Datasheet

Twin M series luminaires deliver stunning performances from an extremely compact body. Perfectly meeting the demanding needs of the most creative architectural lighting spaces, these flexible and versatile luminaires are available in a variety of optical configurations and body finishes.

With DMX512/RDM support, instant status of all LEDs on the luminaire can be monitored. Vibrant and pastel hues are accurately reflected with color depth and gamma corrections. With its high climatic protection class, it works smoothly in harsh environmental conditions.

Options

 RGB Red Green Blue	 RGBW Red Green Blue White	 Tunable White 3000K 5000K 6500K
---	--	--

Control
DMX512/RDM



General Specifications

Twin M DMX/RDM

With its aluminum extrusion body and tempered glass, it is designed to operate smoothly for many years under harsh environmental conditions.

It has universal operating voltage of 110/220VAC.

With DMX512/RDM protocol support, luminaires self-test and provide status and fault detection reports.

It provides visual harmony to architectural structures with its body color options.

Due to DMX512/RDM protocol support, it provides full compatibility with external control software such as Madrix 5, Madrix Radar, ENTTEC ELM.

It allows versatile use with its compact structure and high efficiency LEDs.

It is compatible with various architectural structures with its wide lens options.



IP67



RDM

With the DMX512/RDM Protocol, two-way communication is provided for LED luminaires. In this way, it is ensured that the systems are sustainable by receiving feedback from the luminaires. From all product ranges in the Twin M DMX512/RDM product family; Temperature, Input Voltage, Working Time, Working Current information are instantly transferred to the control computer.

With the Twin M DMX512/RDM product family, fault detection of all luminaires can be made uniquely from its competitors. In this way, malfunctions occurring in the systems are tracked from the control computer and transmitted instantly to authorized persons via e-mail.

In addition to fault detection, when requested, faulty luminaires are automatically disabled by the system, preventing the formation of a bad image on the building.

Technical Specifications

Twin M DMX/RDM

General

Control DMX512/RDM
Color Depth 16,7 Million

Physical

Size 2 23/64" x 1 13/16"
Body Aluminum Extrusion
Connections IP67 Connector
Working Temperature -13 °F ~ 122°F
Protection Class IP67

* Product lengths may vary. For details, see the technical drawing section.

Optical

Luminous Flux (*1) 1170lm, 2340lm, 3510lm, 4680lm
Beam Angle (*2) 2160lm, 4320lm, 6480lm, 8640lm
10°, 25°, 45°, 60°, 10°x35°, 10°x60°

*1 Lumen values are given for RGB LEDs for Wash M 030, Wash M 060, Wash M 090 and Wash M 120, respectively.
*2 Lumen values are given for Tunable White LEDs for Wash M 030, Wash M 060, Wash M 090 and Wash M 120, respectively.

Electrical

Power (*1) 18W, 36W, 54W, 72W
Operating Voltage 110/220VAC

* Power values are given for Wash M 030, Wash M 060, Wash M 090 and Wash M 120 and all LEDs are lit at full power, respectively.

It offers compact design with built-in power supply and DMX512/RDM driver

Technical Drawing

Twin M DMX/RDM

Twin M 030

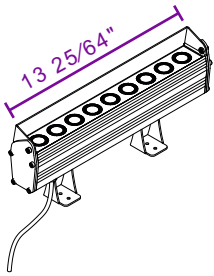

Twin M 060

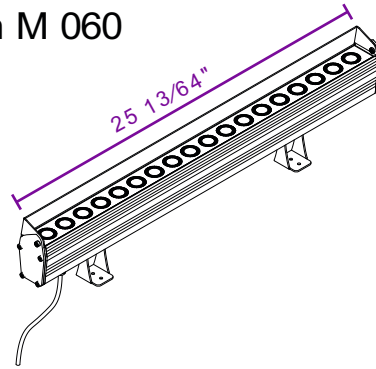

Twin M 090

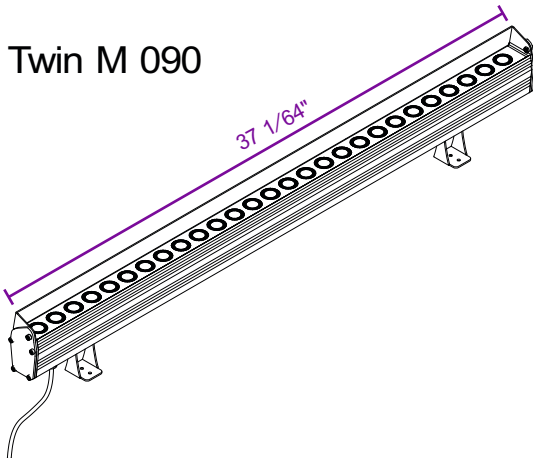

Twin M 120

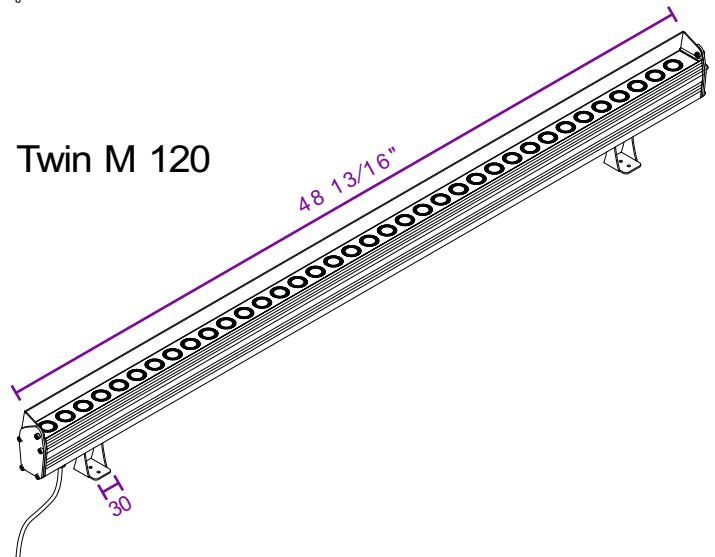

Options

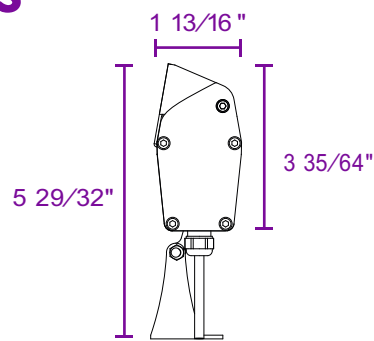

With antiglare

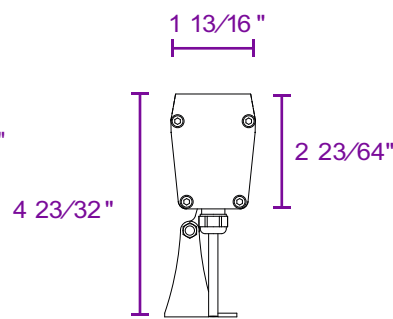

Without antiglare

All dimensions are in inches

Accessories

Twin M DMX/RDM

Connection Accessories



Extension cable



Input cable

Mounting Accessories



Mounting bracket



Socket Pliers



M4 Allen Key

Connection Diagram

Twin M DMX/RDM

